

MAINTENANCE AND INSTALLATION MANUAL

Aerators

- Aéroflott
- Aéroxyde



2005 (april version)

R&O
WATER TREATMENT
EQUIPMENT

CONTENTS

	<i>Pages</i>
1 FOREWORD	3
2 GUARANTEE / LIABILITY	3
3 SAFETY AND ENVIRONMENT	4
3.1 Symbols	4
3.2 General safety instructions	4
3.3 Environment	4
4 TECHNICAL DATA	5
4.1 General	5
4.2 Main parts	5
5 FIRST AERATOR START	6
5.1 Delivery check	6
5.2 Oil level	6
5.3 Power supply	6
5.4 Thermostiches	6
5.5 Cable entry	6
5.6 Motor protection	6
5.7 Motor check	7
5.8 Installation accessories	7
5.9 Direction of rotation	7
5.10 Motor load	8
5.11 Medium temperature	8
5.12 Number of starts	8
6 INSTALLATION MODES	9
7 MAINTENANCE	9
7.1 General	9
7.2 Maintenance schedule	9
7.3 Lubricants	9
7.4 Cable entry	10
7.5 Oil level	10
7.6 Oil change	11
7.7 Motor housing	11
8 TRANSPORT AND STORAGE	11
9 TROUBLE SHOOTING	12
9.1 Safety	12
9.2 Trouble shooting	12
Appendix 1: Preventive maintenance form	13
Appendix 2: List of orders / AEROFLOTT	14
Appendix 3: Cable markings	15
Appendix 4: Wiring Diagrams and principles	16
Marked cross-sections	17-18
Spare parts	19-20
Spare kits	21-22

FOREWORD

Congratulations for having chosen an R&O aerator. It will ensure many hours of safe, economic operation provided that you strictly comply with the maintenance instructions given in this manual.

Proper use and regular maintenance will prolong the life of your aerator.

This manual contains various warning and safety instructions.

Read it carefully to avoid dangerous situations, physical injury and material damage.

 • **Aéroflott and Aéroxyde are for professional use only.**

 • **Servicing and maintenance shall be carried out only by a qualified person who has read this manual.**



• **Basic version aerators shall be used only in an explosion - proof environment.**

To order spare parts or to obtain information about your aerator, please contact your dealer.

Remember to give the following information with your order:

1. Type of aerator*
2. Motor code*
3. Serial number*

* See Dataplate

Cross-section illustrations and spare parts list are available upon request.

All products sold by R&O dépollution S.A.S. are manufactured with the greatest care and comply with our international standards.

Don't hesitate to contact us if you have any suggestions concerning our product range and/or comments to make about this manual in order to improve it:



3, Avenue Georges Clemenceau - 93420 VILLEPINTE - FRANCE

tel.: (+33-1) 41 51 18 18 / fax: (+33-1) 41 51 41 11

e-mail: info@r-o-equipment.com

www.r-o-equipment.com

GUARANTEE / LIABILITY

Refer to the distributor's standard term and conditions of sale.

3.1 Symbols

In this manual:



Danger
Potential danger



Warning

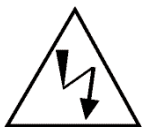

Potential electrical shock

On aerator:

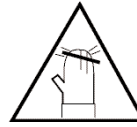

Rotating parts!
Potential physical injury



Label of conformity

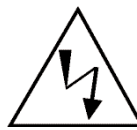

Potential electrical shock

3.2 General safety instructions

- Only qualified persons may install and maintain this aerator after having carefully read this manual.
- Only use this aerator for its initial application and in compliance with applicable laws and regulations.
- Keep clear of rotating parts.
- Clean aerator before every inspection and, or maintenance procedure.
- Comply with applicable laws and regulations when working with harmful, corrosive, toxic, inflammable and explosive chemicals.
- Never remove safety strickers. Clean them.
- Always earth aerator.
- Disconnect all electrical power from aerator when performing inspections and/or maintenance operations.
- Use lifting/hoisting devices properly suited for aerator weight.
- Do not allow too much cable slack in liquid so as not to be damaged by aerator impeller.
- Never immerse cable end in water. Water may seep into cable and flow into electric motor leading to serious damage.

3.3 Environment

One of the basic design components of aerators is the compatibility of their use in natural environment.

The use of non-toxic lubricants prevents any potential environmental pollution.

When replacing certain aerator components, make sure of proper re-cycling and storage of faulty parts, in compliance with applicable environmental protection laws and directives.

4.1 General

Aéroflott and Aéroxyde aerators are fitted with two-stage impellers. One is used for mixing, the other for gas diffusion. High efficiency motor standard class F insulation (155 °C). Two separate mechanical seals rotate in an oil sump. Bearings: designed for heavy-duty use. Ball bearings are over-sized. 2-stage 316 L stainless steel impeller.

4.2 Main parts

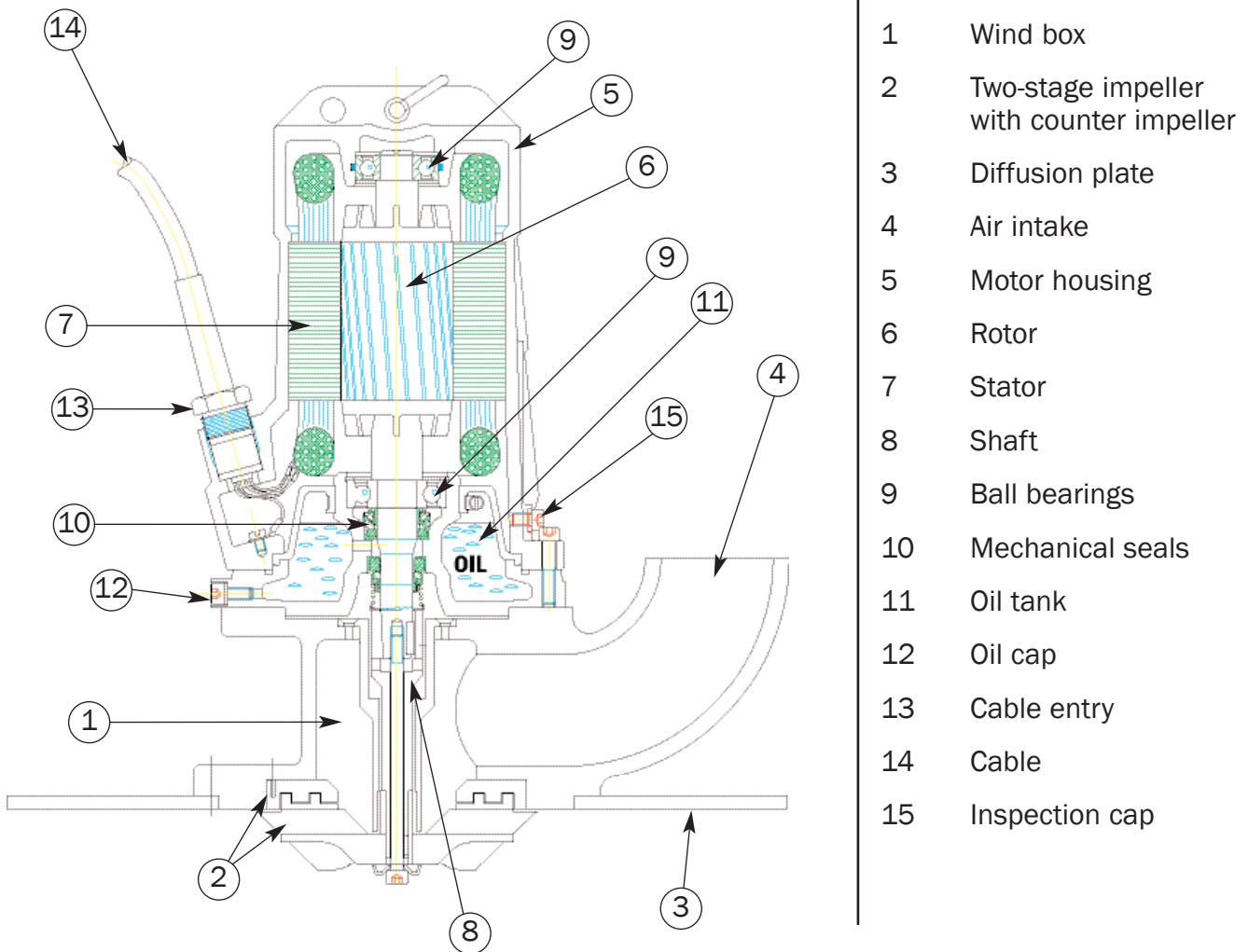

FIRST AERATOR START

5.1 Delivery check

Check for possible damage caused by transport. The cable should be inspected with great care. Avoid severe shocks to aerator when handling. Such shocks may not only damage the aerator but also the seals.



Make sure that your delivery includes all items ordered!

5.2 Oil level

Check oil level.

5.3 Power supply

Before connecting aerator to mains, check that voltage and frequency correspond to those indicated on ID plate.

Check that thermostats are properly connected if installed. Refer to drawings (see appendixes 3 and 4).

5.4 Thermostitches

As an option, aerators may be fitted with thermostats in motor winding.

If these thermostats are installed, check that they are properly connected. Maximum thermostats load: 250 VAC – 1,6A.

5.5 Cable entry

Before starting aerator, ensure cable gland tightness, especially after long-term storage. Do not over-tighten so as not to damage rubber seal of gland (refer to paragraph 7.4.).

5.6 Motor protection

The aerator motor shall be connected to mains via a circuit-breaker and motor fuses. Fuses shall be correctly calibrated.

In direct start mode, switch must be connected as indicated on ID plate.

For triangle/star-connected start, it is preferable to install the safety relay immediately after the main switch. In this case, the motor is also protected for a star connection.

The maximum adjustment for the safety-relay may be 0,6 X the intensity indicated on the Id plate.

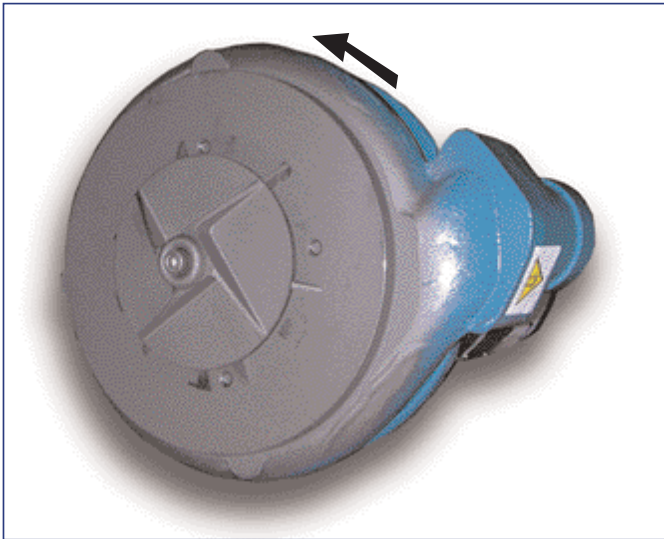

Fig. 5.1

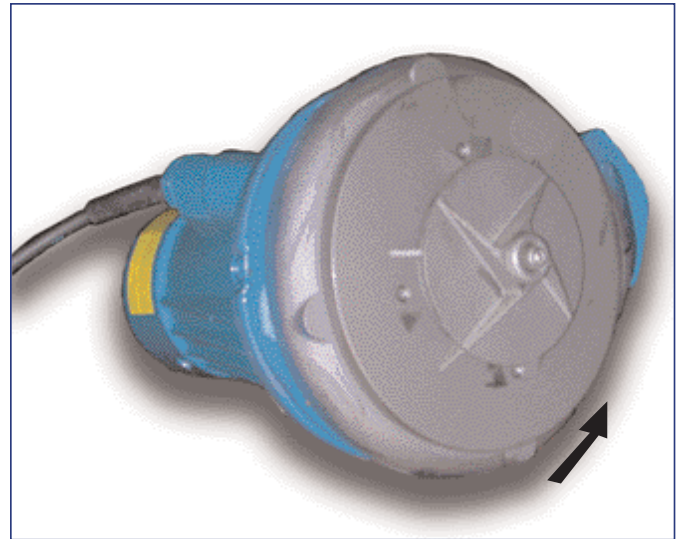

Fig. 5.2

5.7 Motor check

If you are not sure about the condition of the motor, test motor winding with an ohmmeter. The resistance between the latter and the earth wire must be 1 Mega Ohm.

Make sure that the impeller rotates freely when it is touched, in the direction of the arrow. This procedure allows for unsticking and lubricating the surface of the mechanical seals (Fig. 5.1).

5.8 Installation accessories

Check that all parts needed for your installation have been delivered.

5.9 Direction of rotation

The proper rotating direction of the motor must be checked in the following way:

Place aerator horizontally (Fig 5.2).

When powered, the impeller should turn counter-clockwise.

If required, to obtain the proper direction of rotation, invert two of the three phases of the power supply cable.



Danger, recoil!

5.10 Motor load

When starting, check on a phase that the amperage corresponds to that indicated on the Dataplate.

- **Place the cable in such a way that it is not damaged by the impeller.**

If the amperage is too high, check the following points:

- voltage (lower voltage?)
- density and viscosity of process product
- impeller jamming
- proper rotating direction

If the problem persists, contact your dealer.

5.11 Medium temperature

When ambient temperature is greater than 40°C, the motor load must be reduced.

The influence of the ambient temperature on the maximum authorised motor load is shown in the table below.

Temperature (° C)	Max. motor load
40	100
50	95
60	90
70	80
80	70

If the necessary load is higher than that shown on the ID plate, the diameter of the impeller must be reduced, or a more powerful motor chosen.

5.12 Number of starts

Most of the time, aerators operate non-stop.

A number of more than 6 starts per hour will cause abnormal over-heating of the motor and cause excessive impeller clogging.

INSTALLATION MODES

The appliances are designed to be suspended.

- The diffuser disk fitted on F315 – F321 – F330 – F340 and A321 type appliances, can be used as a support for aerator, as long as its function is not disturbed by this.
- A perforated support can be added upon request to F206, F211 and A211 type appliances.
- The aerators have a threaded sleeve for fitting the air intake tube.
- The diameter of the tube must correspond to the factory installed sleeve.

Never support the aerator by the air intake tube : use the chain provided for this purpose.

Never restrict air intake without our prior agreement, as this could lead to motor overload.

MAINTENANCE

7.1 General

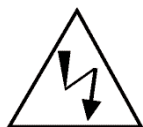

Make sure power is cut off when working on motor.



Wear safety clothing. Aerator may be chemically contaminated.
When stopped, motor housing may be hot.

7.2 Maintenance schedule (cf Appendix 1)

It is necessary to check the impeller every six months or 5000 hours of operation.

Make a complete oil change if oil is no longer limpid.

7.3 Lubricants

Motor bearings are permanently self-lubricants and do not require maintenance.

As a standard feature, the oil tank is filled with Shell Naturelle HF-R oil. This lubricant is compatible with the natural environment, but may also be mixed with mineral oils of a compatible viscosity. For example, Cofraline Equitex 68.

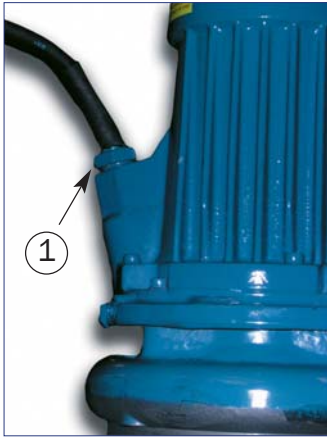

Fig 7.1

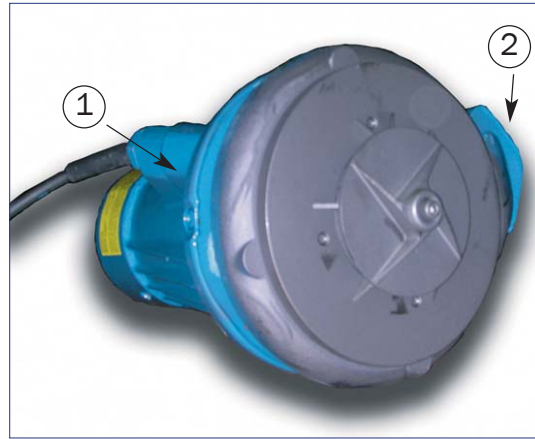

Fig 7.2

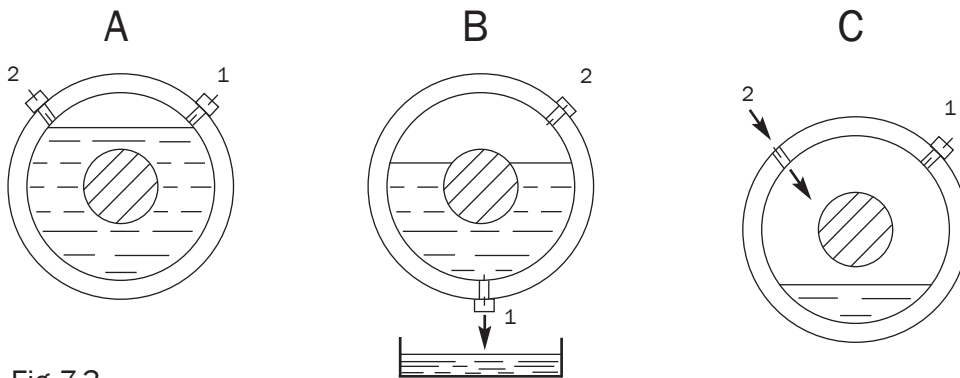

Fig 7.3

7.4 Cable entry

When the aerator has been running for a long time, and especially in this case, the inlet cable rubber seal may not be tight enough.

This may lead to leakage.

Re-tighten gland to correct this problem.

Turn cable inlet hex head (1) clockwise 1/6 of a turn using a suitable wrench (Fig. 7.1.).

7.5 Oil level

It is necessary to check oil level after each inspection of appliance following the bellow-mentioned procedure:

Place aerator horizontally so that hex caps are on top (Fig.7.2.).

Unscrew oil level (1) and breather cap (2).

Oil level shall reach lower edge of holes (see Fig. 7.3. position A).

This can be seen by slightly turning pump.

Top up if necessary.



Always use required oil !

7.6 Oil change



Oil collection, storage and transport shall be carried out in compliance with applicable laws and regulations.



Replace seals as required.

Always use required oil!

For all aerator types (0,6 l oil).

Place appliance horizontally so that one of the caps is on top (see Fig.7.3. position B).
Unscrew breather (2).

Place a drain pan under oil cap (1).

Remove oil drain plug. Turn appliance so that both holes are on top (Fig.7.3. position C).

Fill oil tank. Oil level shall reach lower edge of holes (Fig.7.3. position A).

Install new « Dubo » type seals and tighten plugs.

7.7 Motor housing

Unscrew motor inspection screw (see Fig.7.4. pos. 1).

Place appliance horizontally, inspection hole downward. Water in casing will drain via this hole. A small amount of condensation water is tolerated.



A large amount of water and/or oil indicates an oil chamber leakage problem.

Install new « Dubo » type seals and tighten plugs.

Contact your dealer if needed.

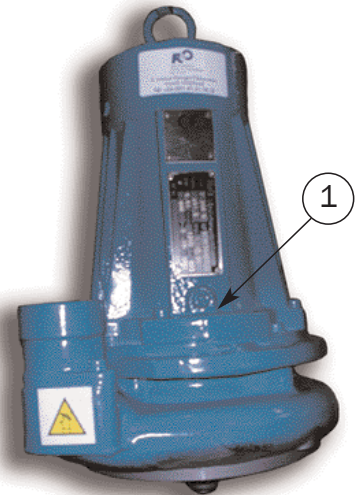

Fig 7.4

TRANSPORT AND STORAGE

The aerator shall be transported and stored in its vertical position.



Never lift aerator by its power supply cable or air intake tube. A hoisting / suspension chain shall be used for this purpose.

The aerator shall be placed in a dry, no-freeze, no-heat area when storing for an extended amount of time.

Cable head insulation shall be given special care.

Hand turn impeller regularly (every 3 months). (see Fig.8.1.).

This procedure frees and lubricates mechanical seal surfaces.

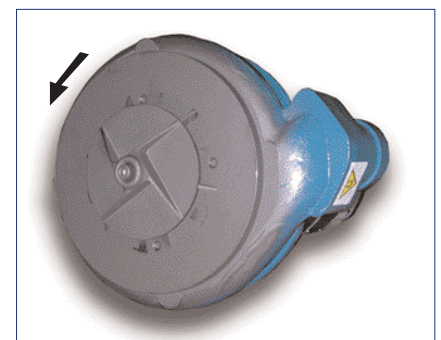

Fig 8.1



Never store the aerator in the air sight after having immersed it (during the starting of the station for example). If necessary, clean the aerator and take down the the impeller before storage.

Such a storage would not allow to keep the mechanical guarantees and the covers given by you dealer.

TROUBLE SHOOTING

9.1 Safety



Make sure power is cut off when working on motor.

Make sure aerator cannot be started unexpectedly when working on hydraulic systems.



Only a qualified electrician may perform repair.



Make sure nobody is near rotating parts when starting.



Comply with local safety practices.

9.2 Trouble shooting (cf Appendix 2)

If aerator does not start or performance does not correspond to its technical characteristics, check the following causes:

1. Impeller jamming or clogging.
2. Impeller or hydraulic plate worm.
3. Inverted direction of rotation.
4. Air intake tube clogged.
5. Immersion too deep.
6. Power supply cable cut.
7. Motor burnt out.
8. Bad fuse.
9. Mains failure.

If the aerator amperage is too high (the fuse must brake), impeller should be unscrewed and counter impeller baffles (or hydraulic disk) should be cleaned, as well as the air box.

Abnormal noise may be due to a faulty bearing. Replace if necessary.

Circuit-breaker stops the aerator. This may be due to either impeller jamming or electrical fault.

For overall and/or major repair, it is recommended to send the aerator to our workshops.

Always mention manufacturing number (7 digits, followed by one letter, then 3 more digits) and model number when ordering spare parts.

APPENDIX 1: PREVENTIVE MAINTENANCE FORM

Type of curative actions (1)	Frequencies (2)	Duration of intervention except handling	Maintenance products et needed quantities	Spare parts	Qualification of worker	Remarks
See manual maintenance and installation manual - delivered with Aerators Change oil	6 months or 5000 hours	30 minutes	SHELL oil natural HFR or COFRALINE EQUITEX 68 0,6 liters	2 DUBO rings Ref. 756 28	qualified electro-mechanician	SEE ILLUSTRATED ORDERS ON MANUAL
Motor water tightness checking by inspection screw	each change oil	5 minutes		1 DUBO ring	qualified electro-mechanician	
Checking and cleaning of impeller and counter impeller chicanes	Once a year when changing oil	30 minutes				

(1) Operation's description (may refer to a document)

(2) In numbers of days and/or in hours of work

APPENDIX 2: LIST OF ORDERS / AEROFLOTT

Contrôles et défauts observés Checking and defaults noticed	Fréquences et causes possibles Frequencies and possible causes	Actions préventives ou curatives Preventive or curative actions
Fonctionnement normal / normal using		
Vidange chambre à huile / change oil	6 mois ou 5000 h / 6 months or 5000 h	Changer 2 joints DUBO / change 2 DUBO rings
Contrôle étanchéité moteur / Motor water tightness checking	A la vidange Each change oil	Par vis d'inspection moteur / changer 1 joint DUBO Open motor inspection screw / change 1 DUBO ring
Contrôle eau dans l'huile / Water in oil checking	A la vidange Each change oil	Par vis d'inspection bac à huile / changer 1 joint DUBO Open oil chamber inspection screw / change 1 DUBO ring
Nettoyage des chicanes des turbines et contre-turbines Cleaning of impeller and counter-impeller chicanes	A la vidange Each change oil	Démonter la vis turbine Dismantle the impeller screw
Sens de rotation de la turbine Rotation direction of impeller	A la vidange Each change oil	Anti-horaire en regardant la turbine Anti-clockwise direction
Contrôle visuel de l'état du câble / visual checking of cable	A la vidange / Each change oil	Changer le câble / Change the cable
Incidents / incidents		
Faible rendement dès le démarrage / low efficient at the starting		
	Contrôle de la profondeur d'immersion Immersion depth checking	Remonter l'appareil Take up the aerator
	Obturation du tube d'aspiration par flottants ou déchets Sealing of the aspiration tube by floatings or wastes	Vider le tube, démonter la turbine, nettoyer la contre-turbine et la boîte à vent Empty the tube, dismantle the impeller, clean the counter-impeller and the wind box
Perte d'efficacité / efficient lost		
	Appareil tournant dans le sable / turbine running in sand	Augmenter les fréquences de vidange de sable / increase the sand pumping Diminuer la profondeur d'immersion / decrease the immersion depth
	Obturation du tube d'aspiration par flottants ou déchets Sealing of the aspiration tube by floatings or wastes	Remonter le tube ou baisser le niveau d'eau Lift the tube or lower the water level
	Blocage de la turbine / impeller jamming	Démonter la turbine pour inspection des rondelles de calage / dismantle the impeller for ?
	Usure de la turbine ou contre-turbine / Turbine or counter-turbine wears	Démonter et remplacer / dismantle and replace
Bruit anormal / unusual sound	Roulements défectueux / bearings damaged	Remplacer les roulements / replace bearings
Disjoncteur ou protection thermique sautent Circuit breaker or thermal protection release	Ne réenclencher que 2 fois sans chercher la cause Engage only twice without investigate the cause	
	blocage turbine / impeller jamming défaut électrique / electrical default immersion trop importante / too important immersion depth	Nettoyer chicanes turbines et contre-turbines / Clean impeller and counter-impeller chicanes Vérifier armoire de commande / check electrical panel Vérifier profondeur maxi / check maximum immersion in manual
Arrêt complet / Complete stop	défaut électrique installation / electrical default in installation câble sectionné / cable cut moteur brûlé / motor burnt	Vérifier armoire de commande / check electrical panel Changer le câble, s'assurer de sa bonne installation et vérifier étanchéité / Change the cable, check it's well installed A remplacer / replace motor

Les appareils doivent fonctionner 24 heures sur 24 / The aerators must run 24 hours a day.

Les appareils, une fois immergés, ne doivent plus être sortis de l'eau en fonctionnement normal. Les laisser à l'air libre entraînerait la non application des garanties mécaniques et revêtement.

Don't take the aerators out of water in standard using. Let them out would cancel the mechanical and coating warranties.

APPENDIX 3: CABLE MARKINGS

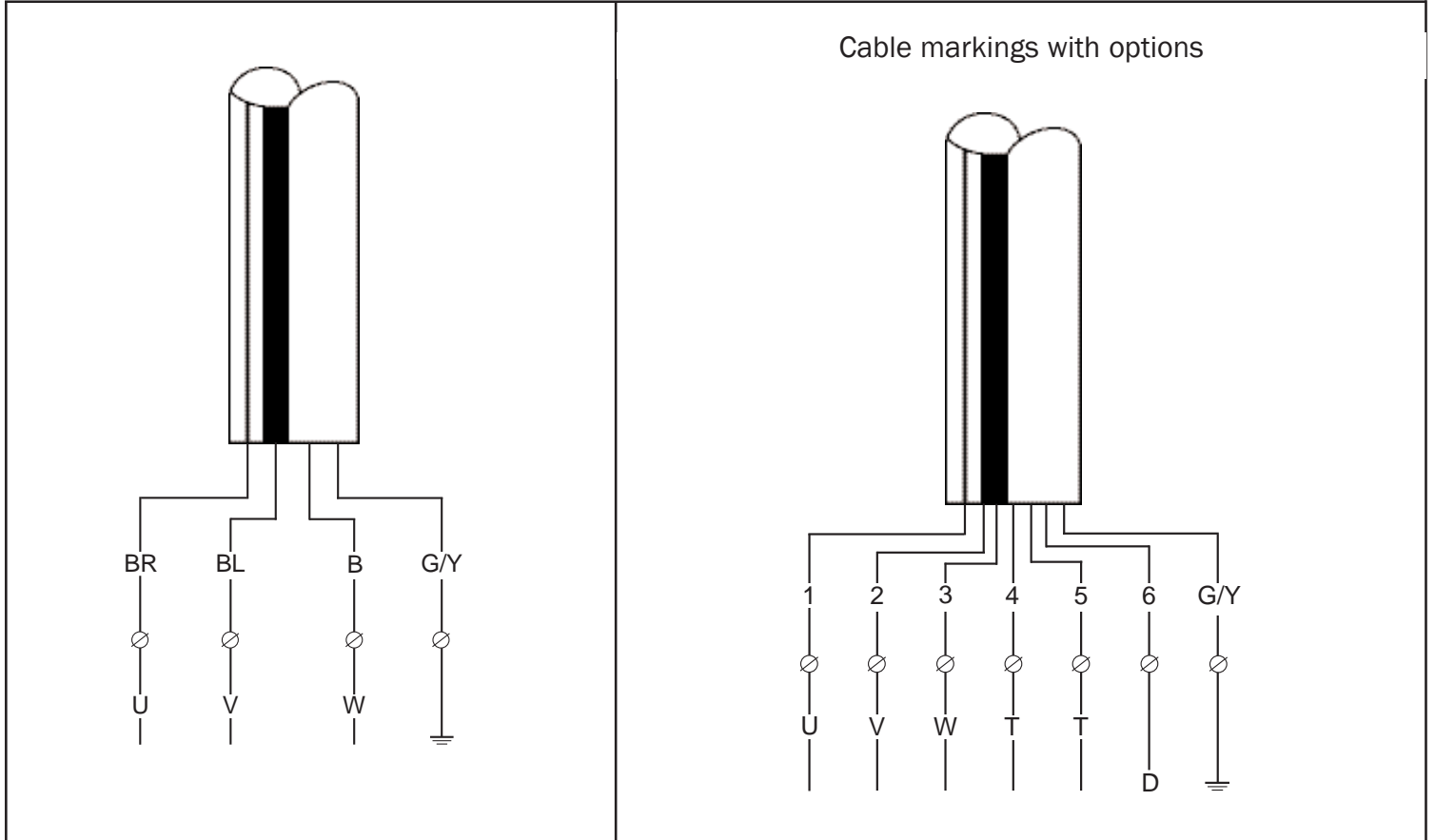

COLOR CODES AND CABLE MARKINGS	
BR = brown	U, V, W = network
BL = blue	T = thermostat
B = black	⊥ = earth
G/Y = green/yellow	D = humidity detector

APPENDIX 4: WIRING DIAGRAMS AND PRINCIPLES

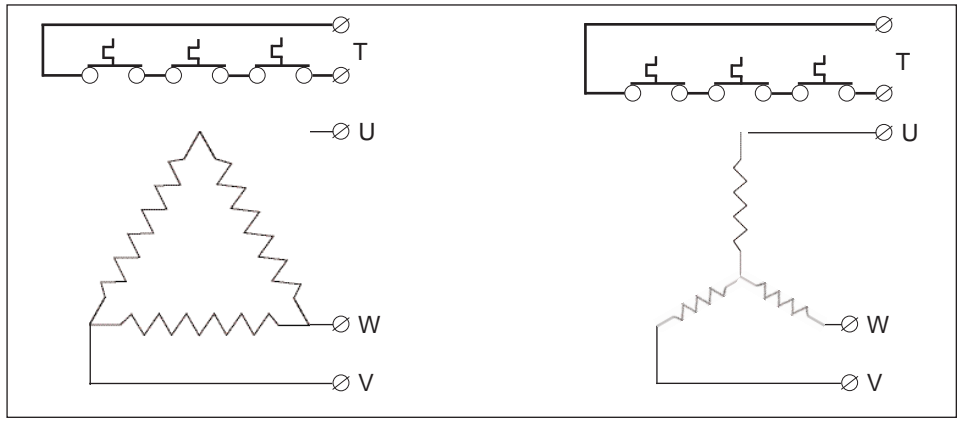
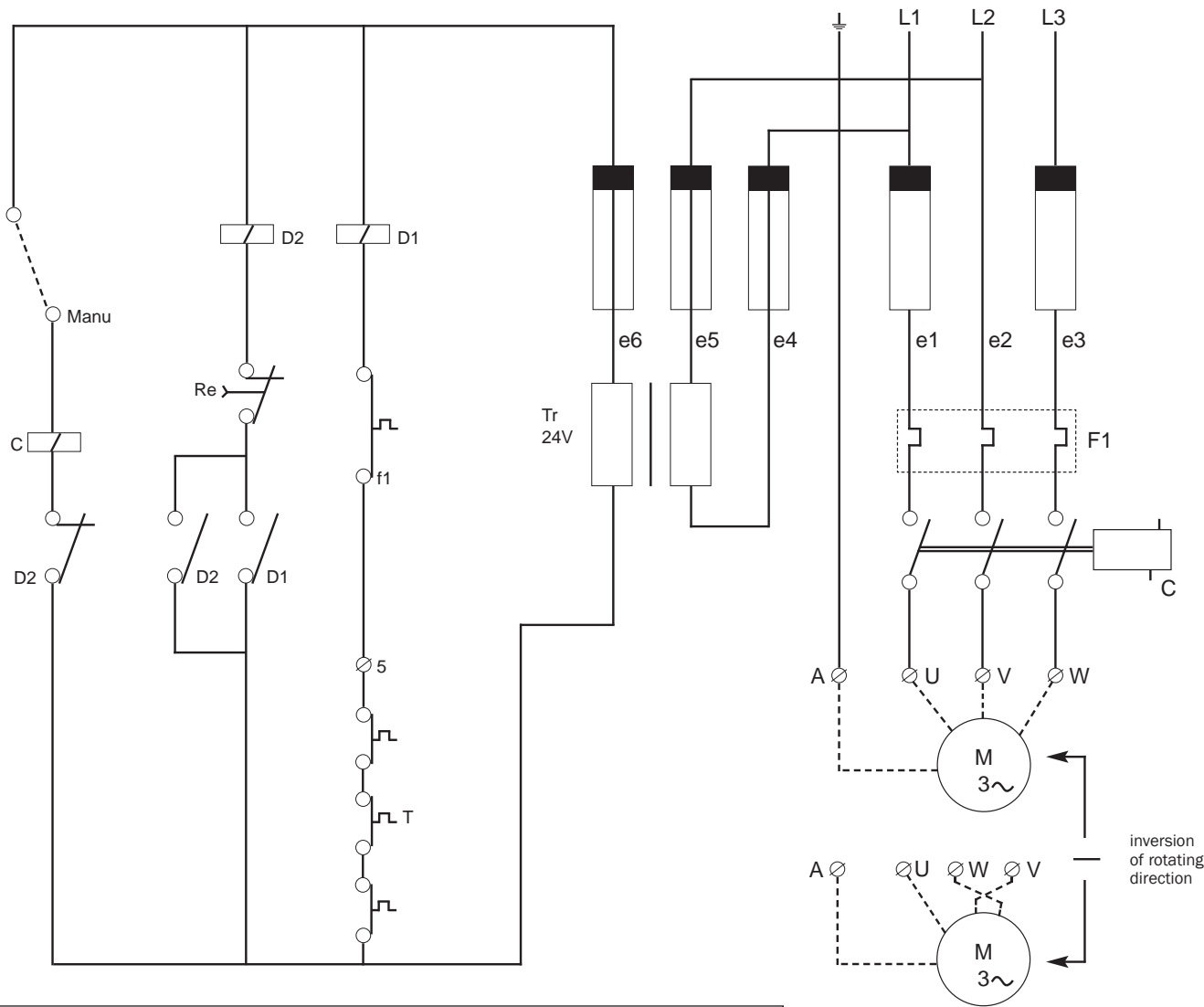

delta-shape motor

star-shape motor

motor connexion

CODES

- | | |
|------------|---|
| e1, e2, e3 | Line fuses |
| e4, e5 | Fuses primary control-circuit |
| e6 | Fuses secondary contrôle-circuit |
| C | Main contactor |
| F1 | Manual triggering averheat safety relay |
| D1 | Auxiliary relay for motor protection |
| D2 | Auxiliary relay for power failure |
| Tr | Transformer |
| S | Manual-on-off-auto selector switch |
| Re | Reset push button |
| M | Aerator motor |
| T | Winding thermostats |

MARKED CROSS-SECTIONS - A 211 / F 206 / F 211 AERATORS

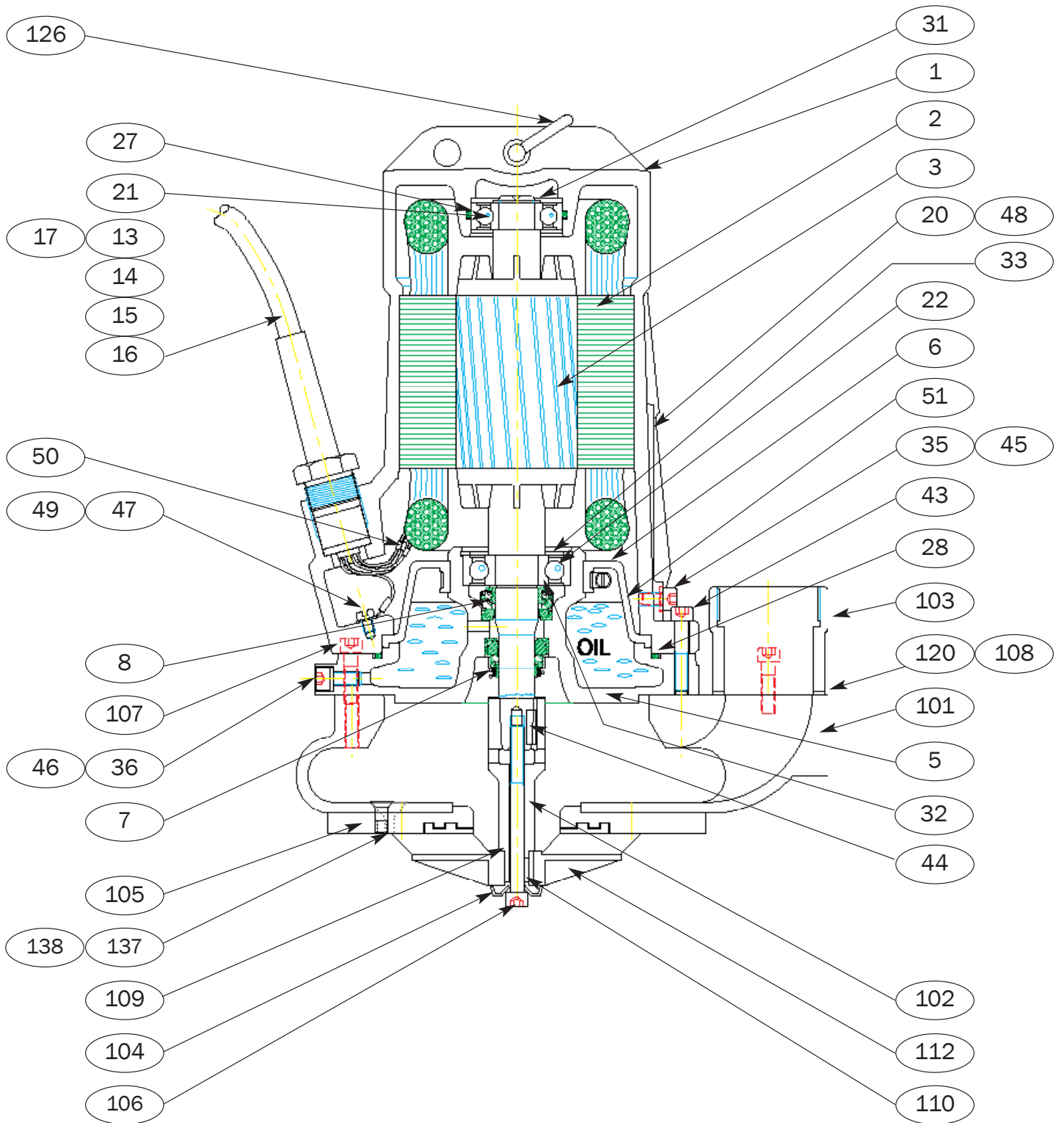

MARKED CROSS-SECTIONS A 321 / F 315 / F 321 / F 330 / F 340 AERATORS

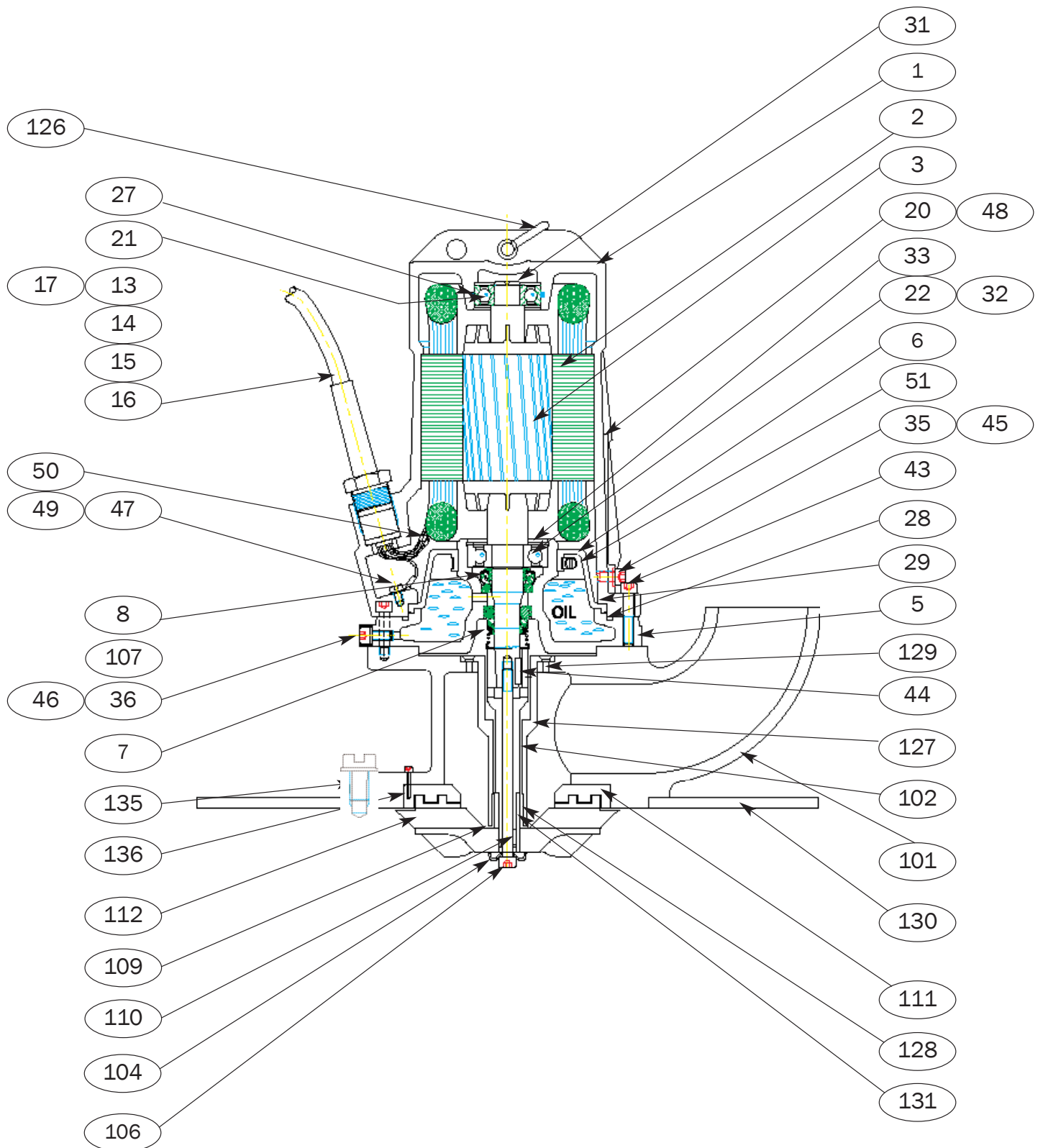

SPARE PARTS

Rep.	Ref.	Item description	Quantity for unit							
			A211	F206	F211	A321	F315	F321	F330	F340
1	700161	Motor housing		1	1					
1	700153	Motor housing	1			1	1	1		
1	700184	Motor housing							1	1
2	702254	Stator 0,65 kW - 1450 rpm		1	1					
2	702367	Stator 1,5 kW - 2850 rpm	1							
2	702318	Stator 2,6 kW - 2850 rpm				1				
2	702258	Stator 2,2 kW - 1450 rpm					1	1		
2	702302	Stator 3,5 kW - 1450 rpm							1	1
3	703370	Rotor shaft 0,65 kW - 1450 rpm		1	1					
3	703367	Rotor shaft 1,5 kW - 2850 rpm	1							
3	703374	Rotor shaft 2,6 kW - 2850 rpm				1				
3	703375	Rotor shaft 2,6 kW - 1450 rpm					1	1		
3	703377	Rotor shaft 3,5 kW - 1450 rpm							1	1
5	704200	Seal housing	1	1	1	1	1	1	1	1
6	704128	Oil housing	1	1	1	1	1	1	1	1
7	706291	Mechanical seal Ø 20	1	1	1	1	1	1	1	1
8	706328	Mechanical seal Ø 25	1	1	1	1	1	1	1	1
13	940 41	Cable 4 x 1,5 mm (709146)	10 m	10 m	10 m	10 m	10 m	10 m		
14	709016	Cable entry	1	1	1	1	1	1		
15	709009	Thrustring	1	1	1	1	1	1		
16	709153	Sleeve	1	1	1	1	1	1		
17	709125	Thrustring	1	1	1	1	1	1		
13	940 47	Câble 4 x 2,5 mm (709147)							10 m	10 m
14	709002	Cable entry							1	1
15	709006	Cable clamp							1	1
	754082	TCHC M6 scREW x 20							2	2
16	709028	Sleeve							1	1
17	709125	Thrustring							1	1
20	513 51	Dataplate	1	1	1	1	1	1	1	1
21	750002	Ball-bearing 6304 2 RS		1	1		1	1	1	1
21	750120	Ball-bearing 6304 2RS C3	1			1				
22	750005	Ball-bearing 6305 2RS	1	1	1	1	1	1	1	1
27	751180	O-ring	1			1	1	1	1	1
28	751093	O-ring	1	1	1	1	1	1	1	1
29	752044	Pressure washer							1	1
31	752002	Circlip	1	1	1	1	1	1	1	1
32	752007	Circlip	1	1	1	1	1	1	1	1
33	752034	Circlip	1	1	1	1	1	1	1	1
35	754157	Hex-socket TCHC M8 x 12	1	1	1	1	1	1	1	1
36	754100	Hex-socket TCHC M8 x 16	2	2	2	2	2	2	2	2
43	754125	Hex-socket TCHC M8 x 40	4	4	4	4	4	4	4	4
44	756130	Key 5 x 5 x 20	1	1	1	1	1	1	1	1
45	756028	Dubo ring	1	1	1	1	1	1	1	1
46	756028	Dubo ring	2	2	2	2	2	2	2	2
47	757083	Grounding-screw	1	1	1	1	1	1	1	1
48	757076	Plate rivet	4	4	4	4	4	4	4	4
49	759002	Cable lug	1	1	1	1	1	1	1	1
50	759007	Sleeve	4	4	4	4	4	4	4	4
51	906 64	Hose clamp	1	1	1	1	1	1	1	1
101	701218	Air box F206 - A211	1	1	1					
101	50103	Air box F315 - F321					1	1		

SPARE PARTS

Rep.	Ref.	Item description	Quantity for unit							
			A211	F206	F211	A321	F315	F321	F330	F340
101	50103A	Air box with anode A321				1				
101	50105	Air box F330 - F340							1	1
102	703387	Motor shaft	1	1						
102	50311	Motor shaft			1					
102	50302	Motor shaft 35 NC D16				1	1	1	1	1
103	712 41	Threaded-connexion 50/60	1	1	1					
104	713150	Impeller hub-cap	1	1	1	1	1	1	1	1
105	50106A	Grooved hydraulic disk	1							
105	50106	Grooved hydraulic		1						
105	50111	Grooved hydraulic			1					
106	55457	Impeller screw TCHC M8 x 100	1	1	1					
106	55456	Impeller screw TCHC M8 x 150				1	1	1	1	1
107	754084	Hex-socket screw TCHC M8 x 35				4	4	4	4	4
107	754125	Hex-socket screw TCHC M8 x 40	4	4	4					
108	754077	Hex-socket screw TCHC M8 x 20	2	2	2					
109	513 45	Torque washer	0 to 5	0 to 5	0 to 5	0 to 5	0 to 5	0 to 5	0 to 5	0 to 5
110	756007	Key 5 x 5 x 12	1	1	1	1	1	1	1	1
111	50107	Counter impeller 3"				1	1	1		
111	50707A	Counter impeller 3"							1	1
112	50806	2-stage impeller Ø 146/6 INOX		1						
112	50807	2-stage impeller Ø 116/6 INOX	1							
112	50801	2-stage impeller Ø 165/6 INOX					1			
112	50802	2-stage impeller Ø 147/6 INOX				1				
112	50811	2-stage impeller Ø 147/6 INOX			1					
112	50803	2-stage impeller Ø 165/12 INOX						1		
112	50804	2-stage impeller Ø 185/12 INOX							1	
112	50805	2-stage impeller Ø 210/12 INOX								1
120	760003	Gasket oval kling	1	1	1					
126	912 02	Shackle	1	1	1	1	1	1	1	1
127	50402	Shaft guide bearing				1	1	1	1	1
128	50607	Bearing packingr [bronze ring]				1	1	1	1	1
129	55402	Screw TFHC M6 X 10				4	4	4	4	4
130	501121	Support disk Ø 500 mn				1	1	1		
130	501126	Support disk Ø 600 mn							1	1
131	506 06	Shaft sleeve				1	1	1	1	1
135	754 29	Screw TCHC M8 x 25				3	3	3	3	3
136	55451	Screw TCHC M4 x 16				3	3	3	3	3
137	55403	Screw TFHC M8 x 16	4	4						
	51606	Anode	1			1				
	55455	Screw TFHC M5 x 35				4				
	758 02	Grower washer M5	4			4				
	755 76	Nut M5	4			4				
	55454	Screw TFHC M5 x 30	4							
138	784086	Screw TFHC M8 x 30			4					
	755033	Nut M8			4					
	758026	Grower washer M8			4					

AEROFLOTT

F 206 - 0,65 kW - 1450 rpm / F211 - 1,1 kW - 1340 rpm
 F 315 - 1,5 kW - 1420 rpm / F 321 - 2,2 kW - 1375 rpm
 F 330 - 3,0 kW - 1385 rpm / F 340 - 4,0 kW - 1385 rpm

AEROXYDE

A 211 - 1,4 kW - 2900 rpm
 A 321 - 2,6 kW - 2900 rpm

Complete sealing kit (réf. KIT0272) F 206 - A 211 - F 211

Ref.	Description	Qty
704128	Oil chamber	1
706291	Mechanical seal Ø 20	1
706328	Mechanical seal Ø 25	1
709153	Seal P.E. 12	1
709028	Seal P.E. 14	1
751093	O-ring	1
751180	O-ring	1
756028	Dubo ring M8	3
760003	Gasket oval kling	1
906 64	Hose clamp for 704128	1

Shaft kit (ref. K503072) - F 206 - A 211

Ref.	Description	Qty
703387	Shaft	1
513 45	Torque washer	3
554 57	Hex-socket screw TCHC M8 x 100	1
713150	Impeller hub cap	1
756130	Key 5 x 5 x 20	1
756007	Key 5 x 5 x 12	1

Kit arbre (réf. K503073) - F 211

Ref.	Description	Qty
503 11	Shaft	1
513 45	Torque washer	3
554 57	Hex-socket screw TCHC M8 x 100	1
713150	Impeller hub cap	1
756130	Key 5 x 5 x 20	1
756007	Key 5 x 5 x 12	1

COMPOSITION OF 0272 & 503042
A 321, F 315, F 321, F 330 and F 340 Aerators KITS

Complete sealing kit (ref. KIT0272)

Ref.	Description	Qty
704128	Oil chamber	1
706291	Mechanical seal Ø 20	1
706328	Mechanical seal Ø 25	1
709153	Seal P.E. 12	1
709028	Seal P.E. 14	1
751093	O-ring	1
751180	O-ring	1
756028	Dubo ring M8	3
760003	Gasket oval kling	1
906 64	Hose clamp for 704128	1

Shaft kit (ref. K503042)

Ref.	Description	Qty
503 02	Shaft (35NCD16)	1
506 06	Shaft sleeve for 703388	1
506 07	Bearing packing (bronze ring) 1	
513 45	Torque washer	3
554 56	Hex-socket screw TCHC M8 x 150	1
713150	Impeller hub cap	1
756130	Key 5 x 5 x 20	1
756007	Key 5 x 5 x 12	1